



# **INCOSE 2006**

## **Foundational Systems Engineering (SE) Patterns for a SE Pattern Language**

Joseph J. Simpson

Mary J. Simpson

July 12, 2006

# Overview

---

- **Pattern Form**
- **General Systems Pattern**
- **Behavior Outcomes Matrix**
- **Exploring Relationships**
  - **Laws of Language**
  - **System Language Design Capability**
  - **Sequential Frameworks**
  - **Abstraction Stacks**
  - **Relationship Types**
- **Summary**

# Pattern Form

## Evocative Name

**Problem Statement** that presents difficulty, uncertainty in situation

**Forces** or tensions that influence pattern application

**Context** within which the pattern will be applied

**Related Patterns** may be connected in some way to current pattern

**Solution** that resolves the problem within the given context

# General Systems Pattern

## General Systems (GS)

**Problem:** Entropy and chaos exist for multiple facets of society as a result of increasingly complex activities

**Forces:** Different values in global community create tensions regarding inputs, outputs, boundaries, applicable transforms

**Context:** Complex sociotechnical, social, and industrial activities require shared approach to reduce entropy and chaos

**Related Patterns:** The general systems pattern will relate to all the patterns that are presented in this paper

**Solution:** Apply a systems approach to reduce entropy, complexity, and start to resolve core issues

# Warfield – Behavior Outcomes Matrix

		Outcomes			
		Problem System		Solution System	
		Description	Diagnosis	Prescription (Design)	
		Implementation			
Behavior	Process	<ul style="list-style-type: none"> <li>Limits</li> <li>Triadic Necessity &amp; Sufficiency</li> <li>Universal Priors</li> </ul>	<ul style="list-style-type: none"> <li>Success &amp; Failure</li> <li>Universal Priors</li> </ul>		<ul style="list-style-type: none"> <li>Gradation</li> <li>Validation</li> </ul>
	Individual	<ul style="list-style-type: none"> <li>Limits</li> <li>Triadic Compatibility</li> <li>Small Displays</li> </ul>		<ul style="list-style-type: none"> <li>Requisite Parsimony</li> <li>Requisite Saliency</li> </ul>	
	Group	<ul style="list-style-type: none"> <li>Limits</li> <li>Uncorrelated Extremes</li> </ul>	<ul style="list-style-type: none"> <li>Inherent Conflict</li> <li>Structural Underconceptualization</li> <li>Diverse Beliefs</li> </ul>	<ul style="list-style-type: none"> <li>Requisite Variety</li> <li>Induced Groupthink</li> </ul>	
	Organizational	<ul style="list-style-type: none"> <li>Limits</li> <li>Organizational Linguistics</li> <li>Vertical Incoherence</li> </ul>	<ul style="list-style-type: none"> <li>Forced Substitution</li> <li>Precluded Resolution</li> <li>Vertical Incoherence</li> </ul>		

# First and Second Laws of Language

---

**1. All communication takes place in shared contextual space**, subject to a fairly complex process of disambiguation, depending on the conditions inherent in the other five Laws. (Six laws total)

## **2. The Law of Variable Context**

If two people share sufficient context, almost any words, including sheer nonsense--or no words at all--will suffice for them to communicate with each other. If two people do not share sufficient context, then not all the words in the world may be enough for them to grasp each other's meaning. Where intermediate degrees of partial, fragmented, or otherwise limited or "noise-distorted" context are shared, communication will be proportionately difficult and/or unsuccessful.

Alexander Gross <http://language.home.sprynet.com/>

# Systems Language Design Capability

## Initial Inter-Relationships Defined: “Pattern of Infrastructure”

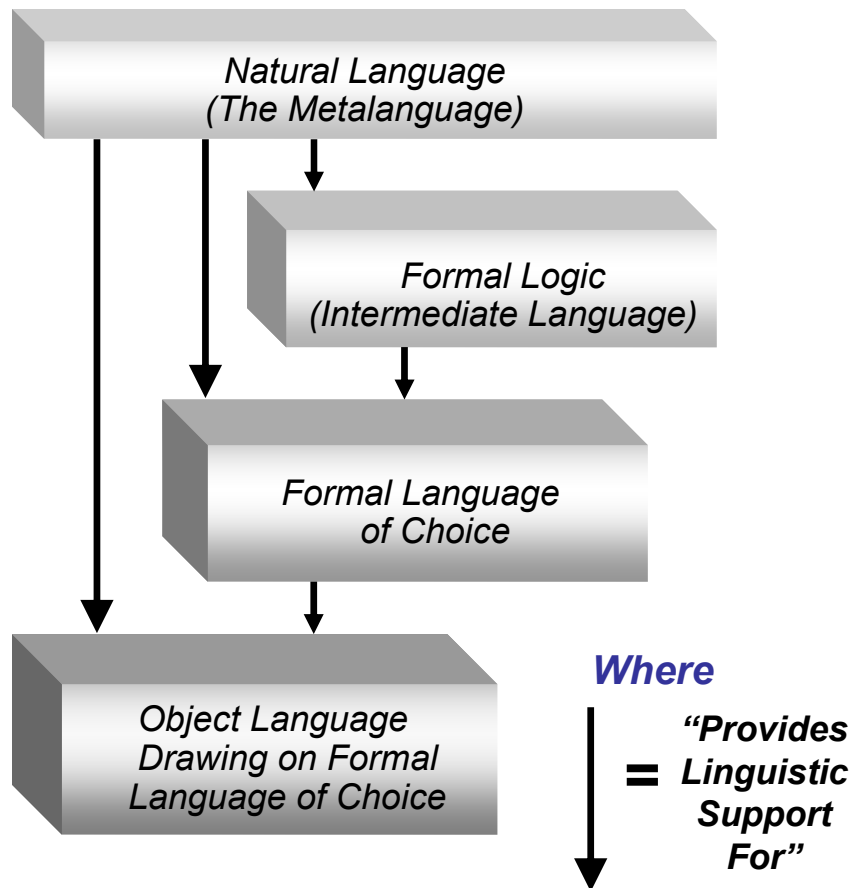

## In Terms of an Abstraction Stack

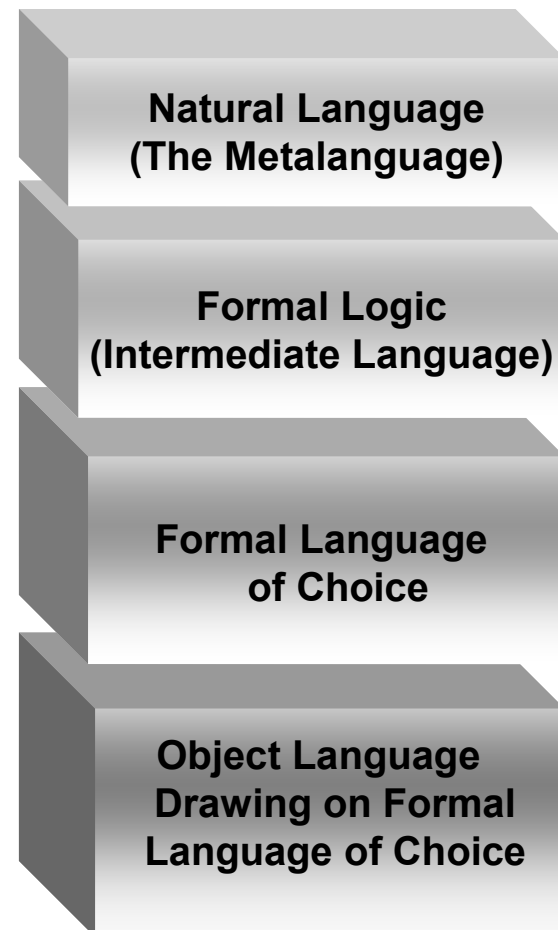

# Sequential Frameworks

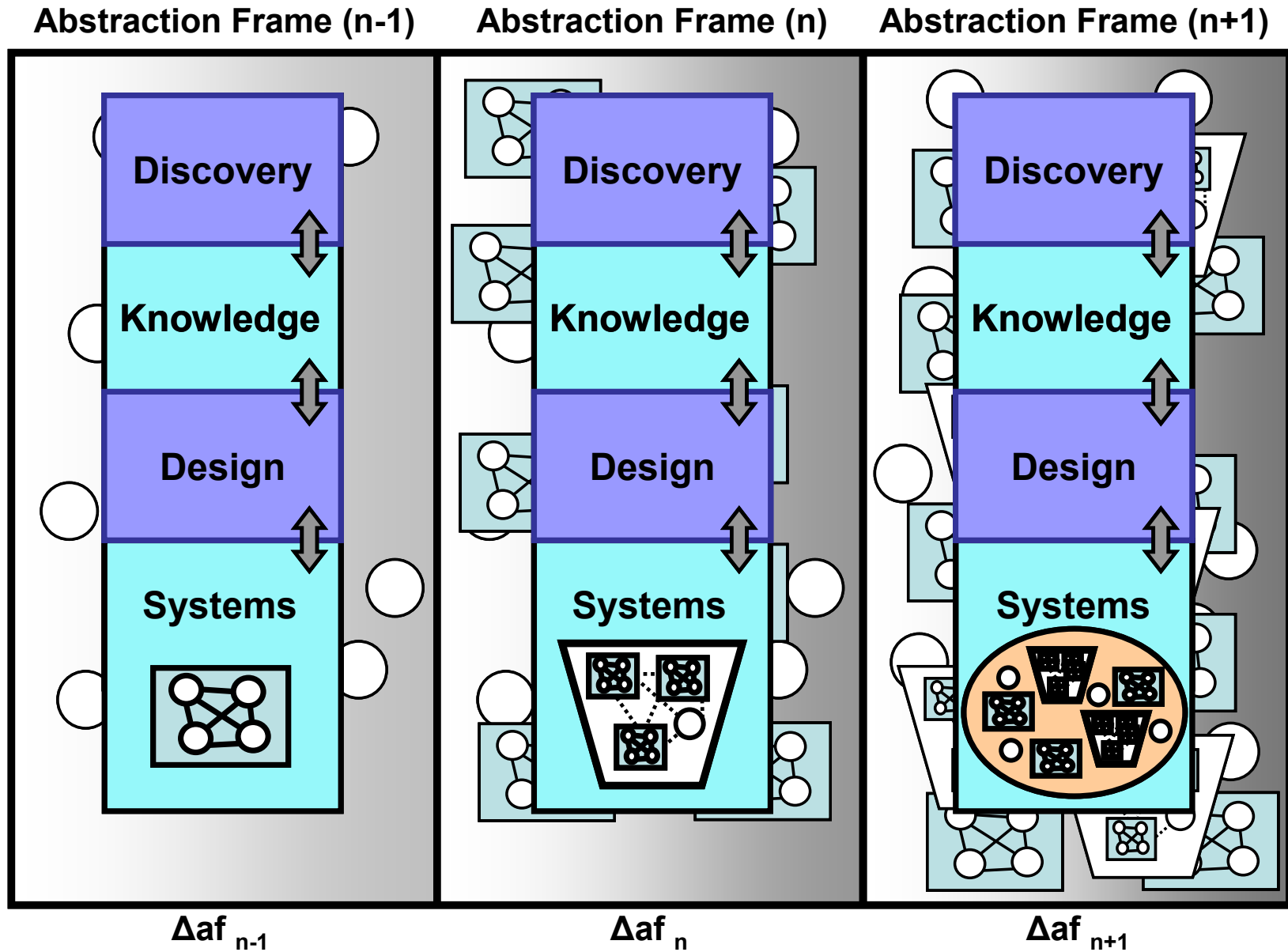

# Abstraction Stacks

A House Consists of:

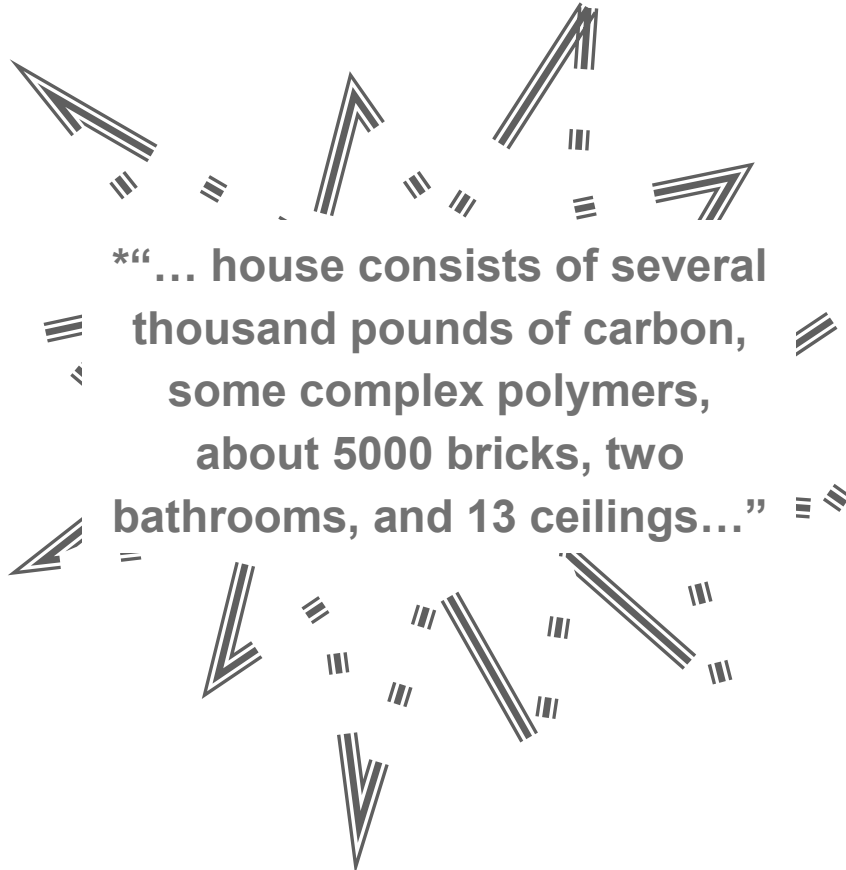

Use of Abstraction ‘Stacks’

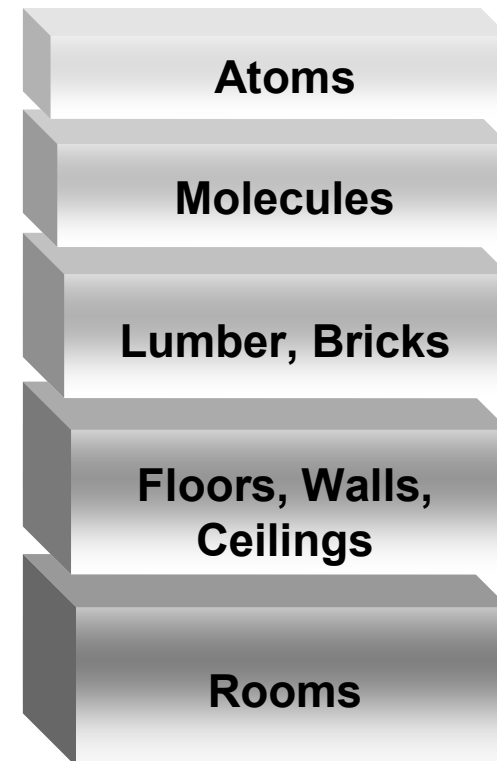

# Relationship Types

**Hierarchical Relationship Type:** “..content can be almost completely disassociated from a hierarchy, but there does not seem to be any way to disassociate structure from it and still portray it.” *Warfield 2003.*

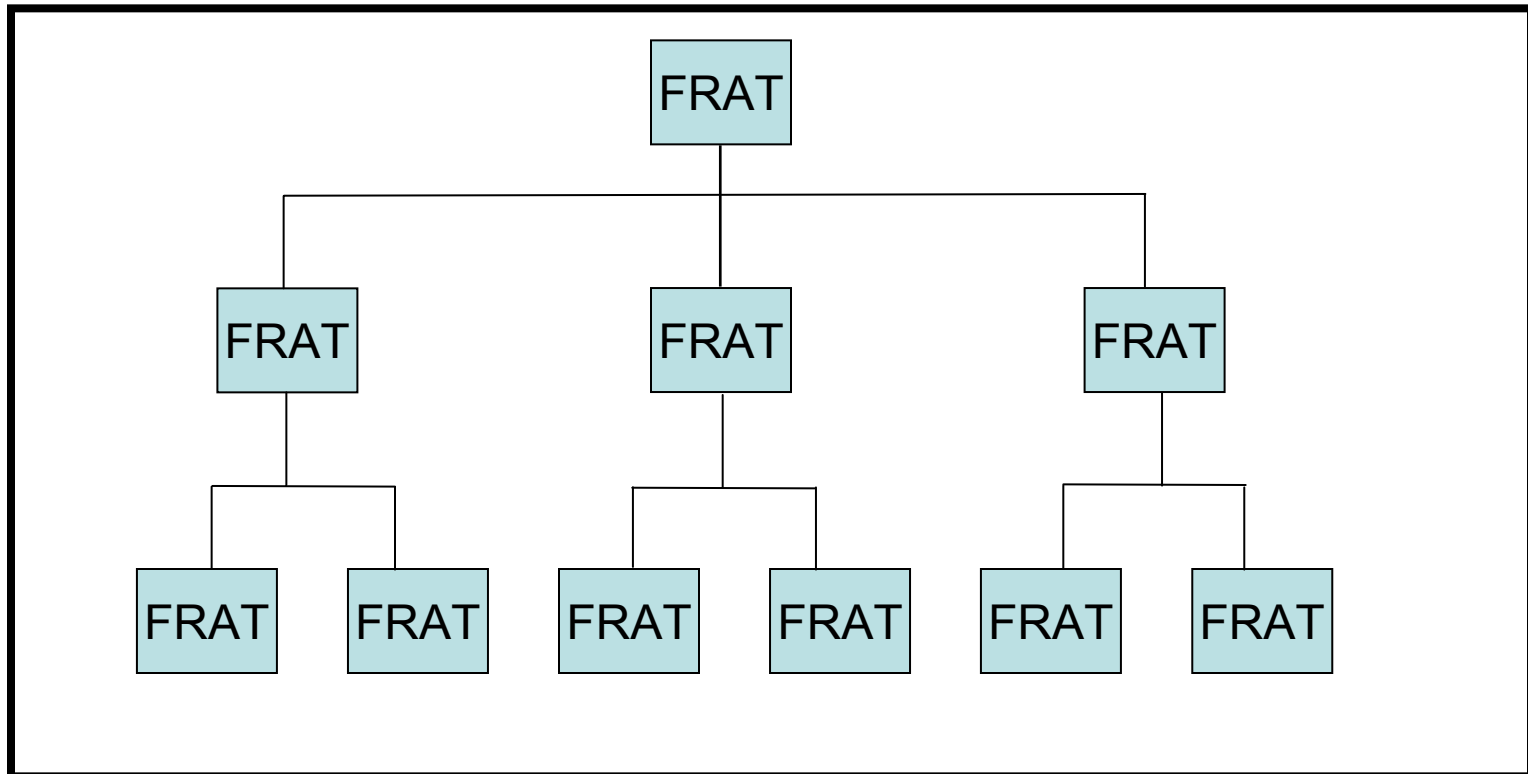

# Functional Decomposition

Functions at each level are equivalent

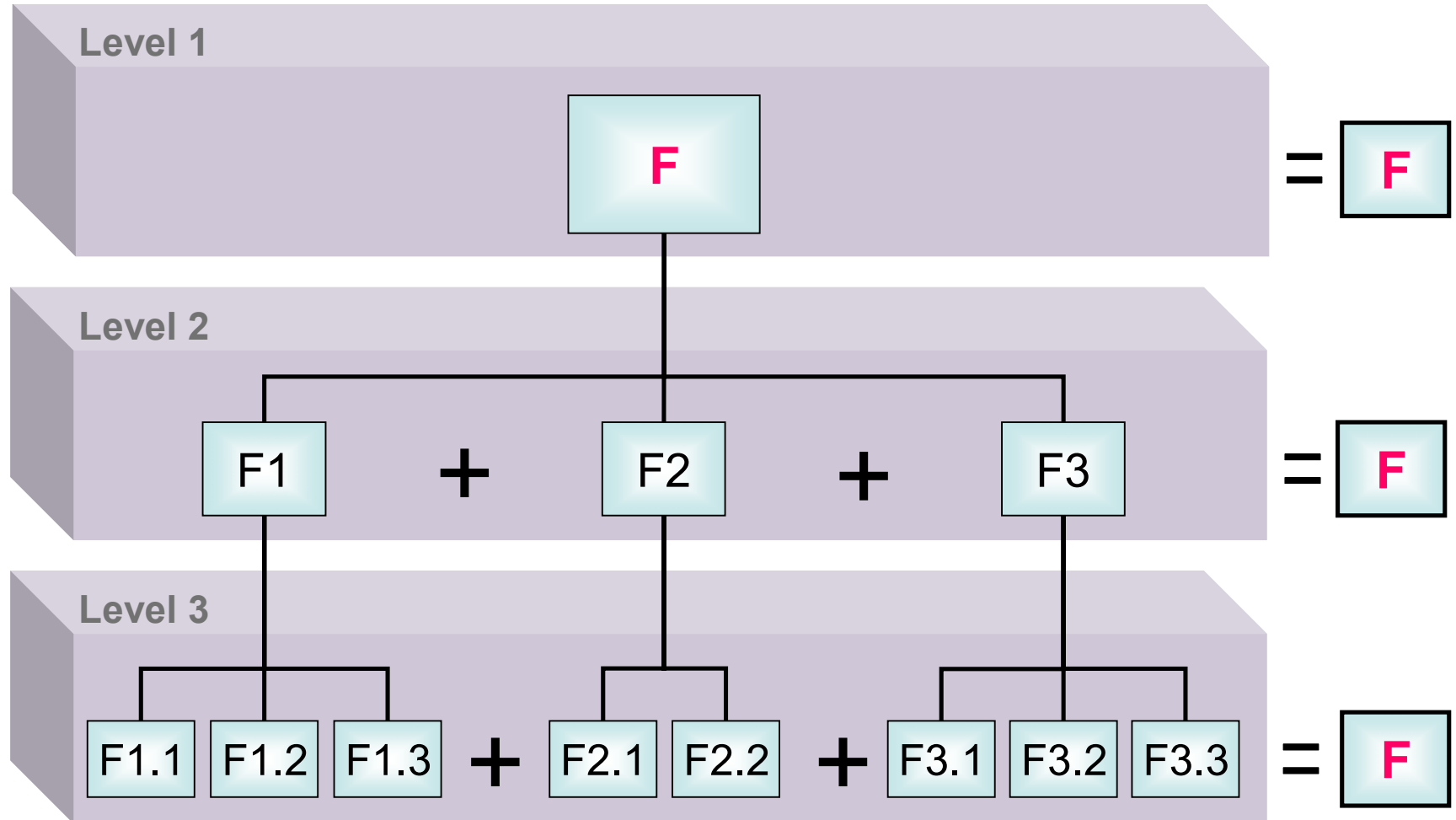

# Physical Architecture Decomposition

Physical architecture parts at each level are equivalent

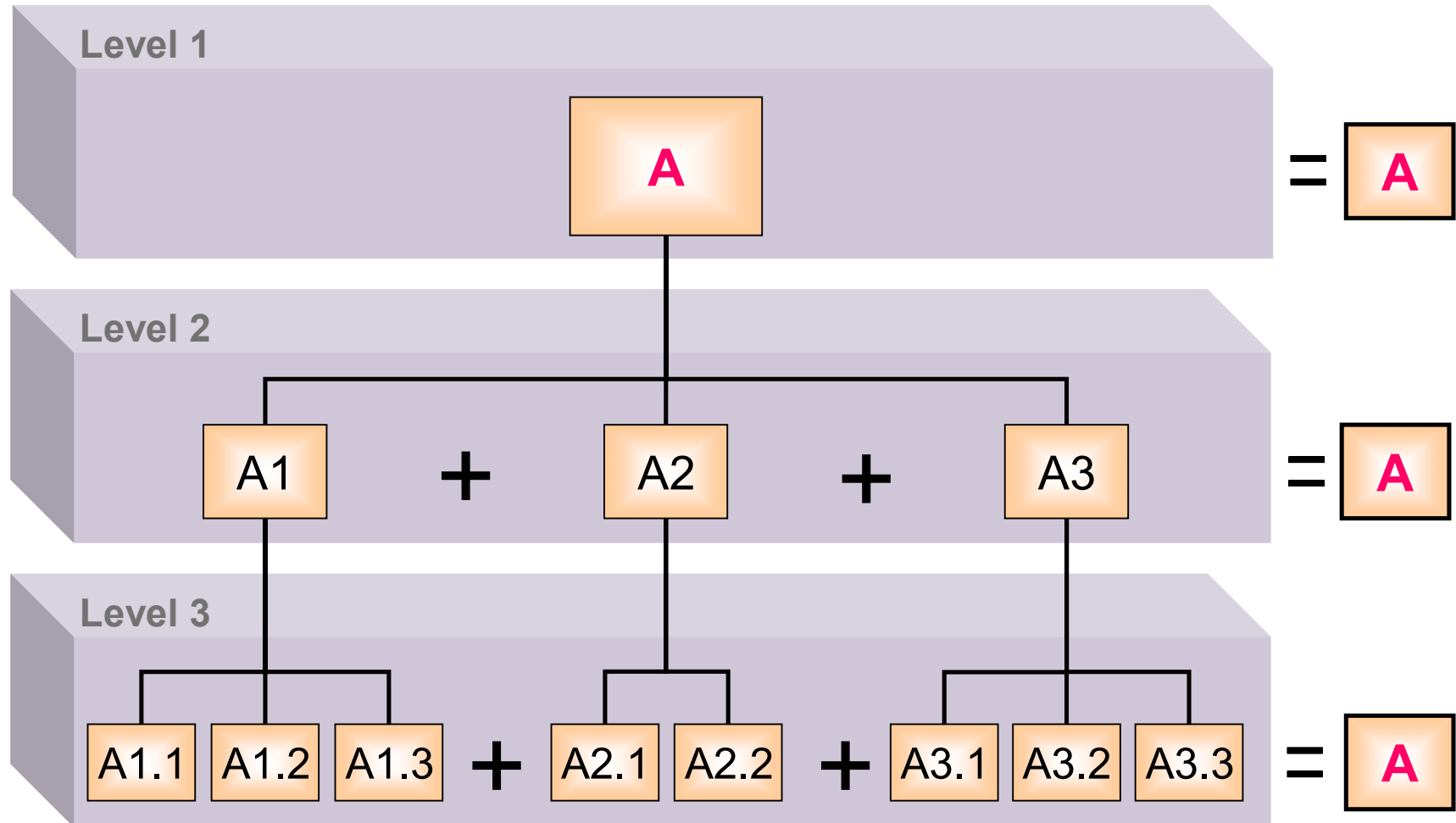

# FRAT Hierarchal Relationships

When

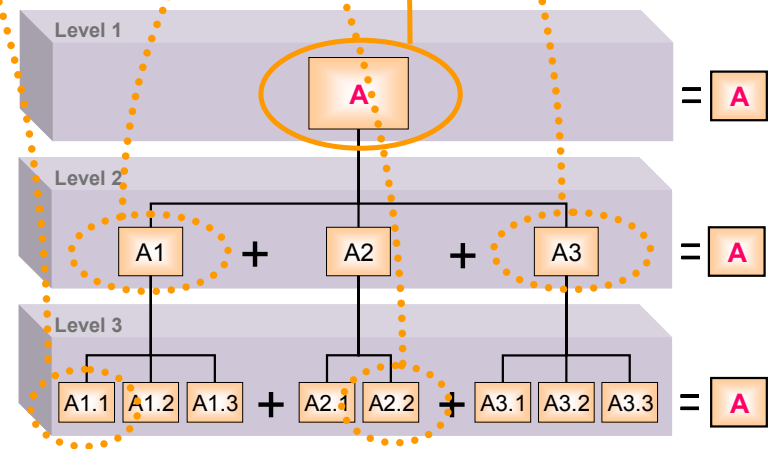
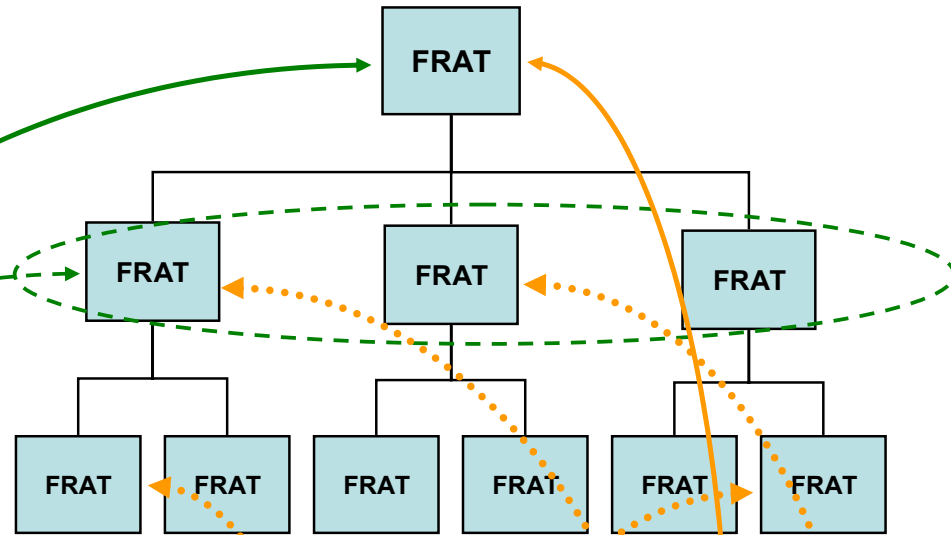
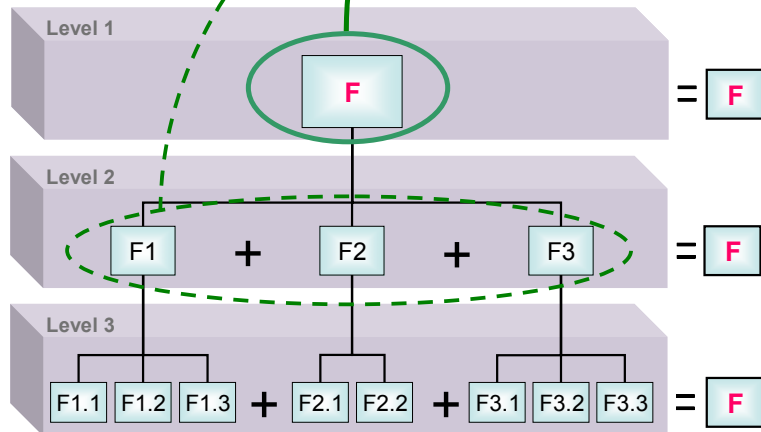

# Summary

---

- Well established and understood SE patterns provide the foundation for the communication of complex systems concepts.
- The 'related patterns' component is a necessary component of the pattern template, and provides the basis for the construction of pattern languages using these related patterns.
- A core set of SE patterns is presented in the paper to stimulate the development and discussion of SE patterns.
- SE patterns are one of the first steps in the representation of shared SE context. The greater the span and depth of the shared SE context, the greater the potential for precise SE communications.